



**ABACO MACHINES**  
**OPERATION MANUAL**  
**ABACO 11" SLAB DOLLY**



**ABACO MACHINES USA, INC.**  
**(EAST COAST OPERATION)**

505 Edwards Court  
Newport News, VA 23608

Tel: 757-877-5243

Fax: 757-877-5863

Email: [sales@abacomachines.com](mailto:sales@abacomachines.com)

Website: [www.abacomachines.com](http://www.abacomachines.com)

**ABACO MACHINES USA, INC.**  
**(WEST COAST OPERATION)**

20224 S. Normandie Ave.  
Torrance, CA 90502

Tel: 310-532-0366

Fax: 310-532-0499

Email: [sales@abacomachines.com](mailto:sales@abacomachines.com)

Website: [www.abacomachines.com](http://www.abacomachines.com)

**ABACO MACHINES**  
**INTERNATIONAL**

Unit 4/34-36 Fairfield Street  
Fairfield N.S.W. 2163 Australia

Tel: 61-2-9632-4990

Fax: 61-2-9632-1510

Email: [abacomachines@abaco.com.au](mailto:abacomachines@abaco.com.au)

Website: [www.abaco.com.au](http://www.abaco.com.au)

**I. PRODUCT OUTLINE**

The Abaco 11" Slab Dolly is designed to facilitate the handling and transporting of slabs on and around the worksite.

The rubber vulcanized channel protects the slabs from chipping and scratching.

The 11" pressurized wheels and heavy duty channel provide additional stability and maneuverability in confined spaces.

**II. STRUCTURE**

The 11" Slab Dolly is constructed from a 4" (100mm) channel and 11" diameter pneumatic wheels.

**Specifications**

Length: 19 $\frac{5}{8}$ " (500mm)

Width: 13" (330mm)

Height: 10 $\frac{5}{8}$ " (270)

Channel Width: 3 $\frac{1}{8}$ " (80mm)

W.L.L.: 600 lbs (275kg)

Net Weight: 22 lbs (10kg)

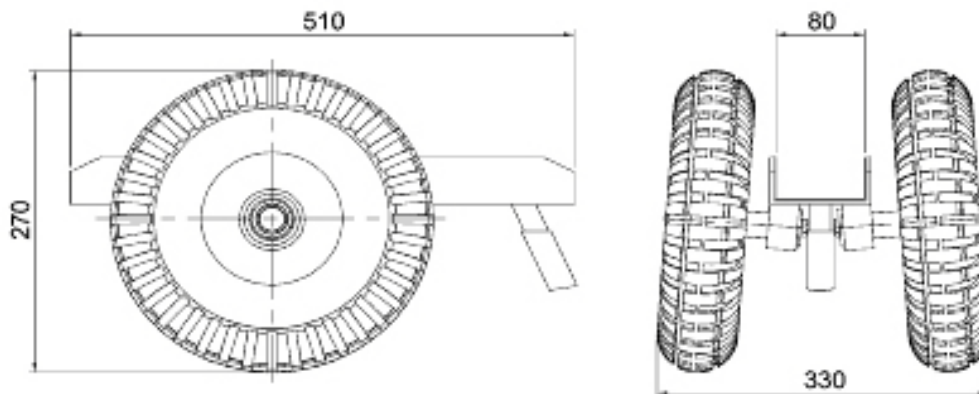

### III. ASSEMBLY INSTRUCTIONS

1. Insert the rubber tube (08) into the body (02).
2. Slot the wheel shaft (03) in the body (02) and lock by the bolts (07) and washers (06).
3. Finally, fix the wheels (04) into the wheel shafts (03) with the washers (01), and then secure by circlips (05).

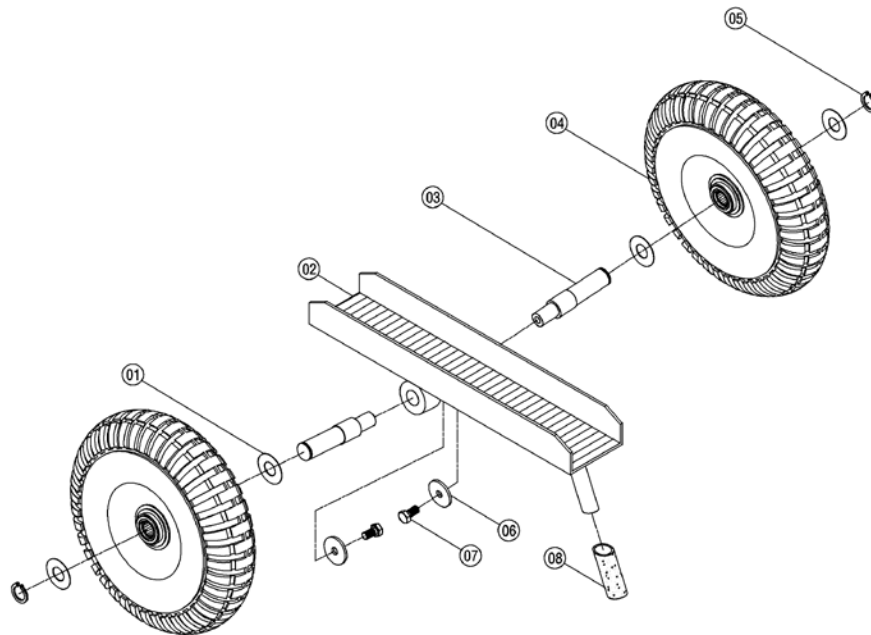

### IV. SPARE PARTS

Number	Description	Qty.
1	Copper Washer $\phi 20$	4
2	Body	1
3	Wheel Shaft	2
4	Pneumatic Wheel $\phi 280$	2
5	External Circlip $\phi 20$	2
6	Washer $\phi 10$	2
7	Bolt M10 x 20	2
8	Rubber Tube	1

## V. INSTRUCTIONS FOR USE

When you want to move a panel, follow this procedure:

1. Place the panel (marble or granite) slightly off center so it can be easily transported.
2. **HOLD** the panel and move the dolly to the desired location



## VI. MAINTENANCE AND INSPECTION

Regularly check the air pressure in the pneumatic wheels.  
Lubricate the shafts and bearings monthly.

## VII. WARRANTY

At the time of delivery, it is necessary to ensure that the Dolly has not been damaged during shipment. Any claims must be presented within eight (8) days of the date of delivery of the product.

We grant you six (6) months warranty on the Dolly counted from the day of purchase.

The warranty coverage is not applicable:

- When the Dolly has been misused.
- When the maximum capacity is exceeded.
- When the damages are due to inadequate maintenance and inspections.
- When damages are due to improper storage.
- When repairs are performed by the user without our permission.
- When non-original spare parts are used.

