



**ABACO MACHINES**  
**OPERATION MANUAL**  
**ABACO DEHYDRATOR**



**ABACO MACHINES USA, INC.**  
**(EAST COAST OPERATION)**

505 Edwards Court  
Newport News, VA 23608

Tel: 757-877-5243

Fax: 757-877-5863

Email: [sales@abacomachines.com](mailto:sales@abacomachines.com)

Website: [www.abacomachines.com](http://www.abacomachines.com)

**ABACO MACHINES USA, INC.**  
**(WEST COAST OPERATION)**

20224 S. Normandie Ave.  
Torrance, CA 90502

Tel: 310-532-0366

Fax: 310-532-0499

Email: [sales@abacomachines.com](mailto:sales@abacomachines.com)

Website: [www.abacomachines.com](http://www.abacomachines.com)

**ABACO MACHINES**  
**INTERNATIONAL**

Unit 4/34-36 Fairfield Street  
Fairfield N.S.W. 2163 Australia

Tel: 61-2-9632-4990

Fax: 61-2-9632-1510

Email: [abacomachines@abaco.com.au](mailto:abacomachines@abaco.com.au)

Website: [www.abaco.com.au](http://www.abaco.com.au)

The Abaco Dehydrator is a dehydration system for fast collection and trapping of the abrasive mud produced by the machining and finishing of marble, granite and other stone.

The Abaco Dehydrator is an economical, one step method in separating and dewatering sludges and slurries. The Dehydrator consists of four basic components: pump, mud holding tank, clean water tray, and filter bags. The Abaco Dehydrator has no moving parts, requires minimal labor, is very economical to use and because it is made of stainless steel, has extremely low maintenance.

### GENERAL CHARACTERISTICS:

Dimensions: L x W x H: 7'4" x 7'2" x 1'9" (2270 x 2220 x 600mm)

Weight: 616.3 lbs (280 kg)

Bag Dimension: L x W: 47¼ x 11 ¾" (1200 x 300mm)

### CONNECTING THE FLOAT SWITCH AND THE SUBMERSIBLE PUMP:

This controls the water level inside the mud holding tank.

- ❖ To avoid serious electrical shock, turn **OFF** the Power source before installing or adjusting this switch.
- ❖ Do not stand on a wet or damp surface during installation.
- ❖ This product must be installed in accordance with national and local codes.

FIGURE E.

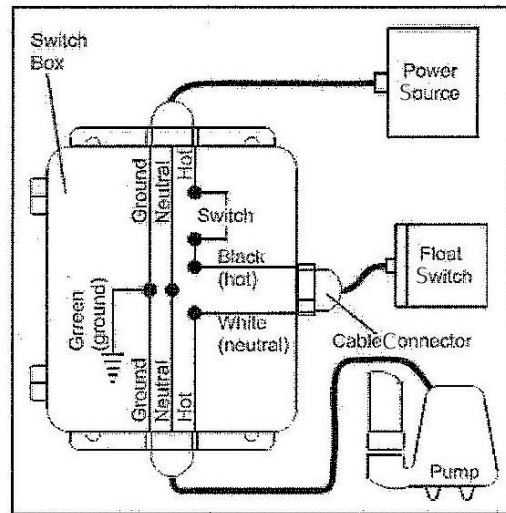

## **FILTER BAGS #ADEFB01**

What to expect with the new filter bags: Within the first 20 minutes of operation, the bag will **not** catch all mud and slurries.

### **How to change the filter bags:**

The filter bag is full and needs changing when the bag is  $\frac{3}{4}$  full of solid slurries.

- a. When the bag is full, turn the water valve off. Let the bag sit for 2-3 days to drain the water.
- b. Undo the stainless steel strap holding the bag.
- c. Remove the rubber band from the bag holder.
- d. Secure the bag and dispose of accordingly.
- e. Replace the rubber band on top of the bag holder.
- f. Attach a new filter bag to the bag holder. Then place the rubber band on the outside of the bag to hold the filter bag in place.
- g. Use the stainless steel strap to secure the bag.

## **AIR STICK**

The purpose of the air stick is to move the settled mud and slurries around in the pit to assist the submersible pump to work more efficiently. It is suggested that the air stick be used a few times per day when the pump is in operation.

- a. Attach the air stick to an air compressor (min. required is 8-10 cfm).
- b. Place the air stick into the pit to stir the settled slurries.

## **MAINTENANCE**

The Abaco Dehydrator has extremely low maintenance requirements.

- a. Periodically hose down the water tray to clean out left over slurries.
- b. Periodically check that the float switch clamp is still attaches. If it requires replacing, buy a hose clamp and secure the float switch according to the water level.
- c. Wipe down the Dehydrator as deemed necessary.

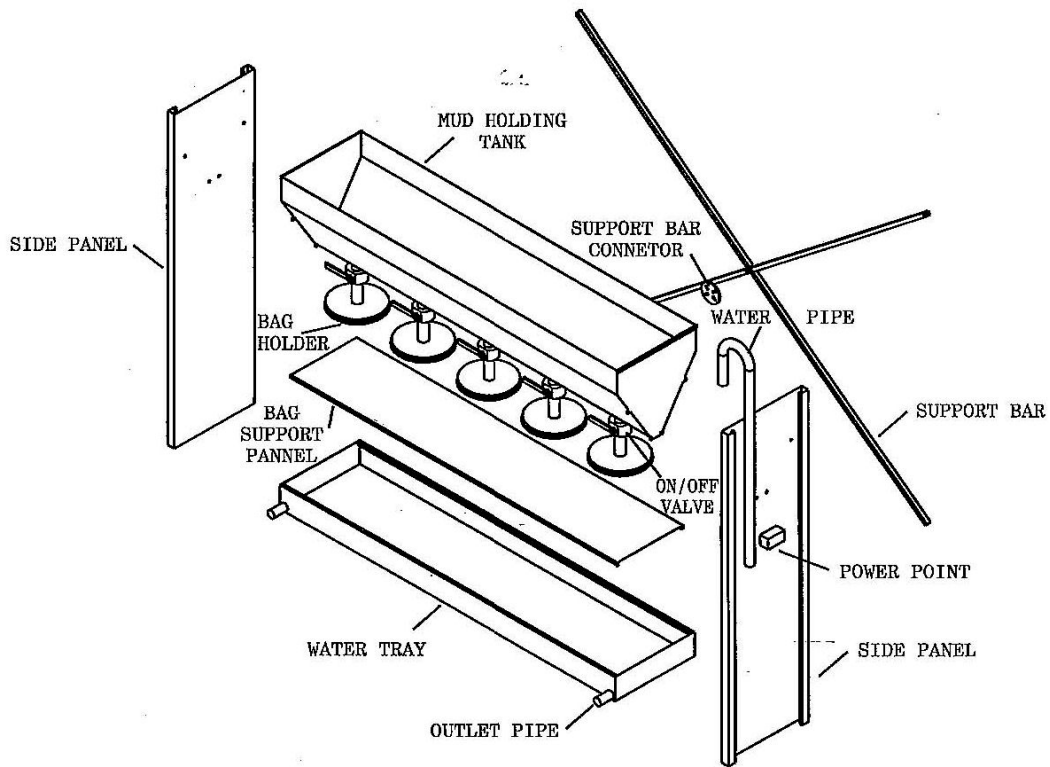

**STEP 1:**

- a. Before turning the mud holding tank upside down, make sure you know which side the floating switch is on.
- b. Place the mud holding tank upside down, as shown on the diagram with the ON/OFF valve facing away from you.
- c. Attach the side panels with the smooth side facing in, making sure the side panel containing the ON/OFF power point matches with the side of the floating switch. Also, make sure the bolt holes are facing you.
- d. Secure the panels using M10 x 16 stainless steel bolts.

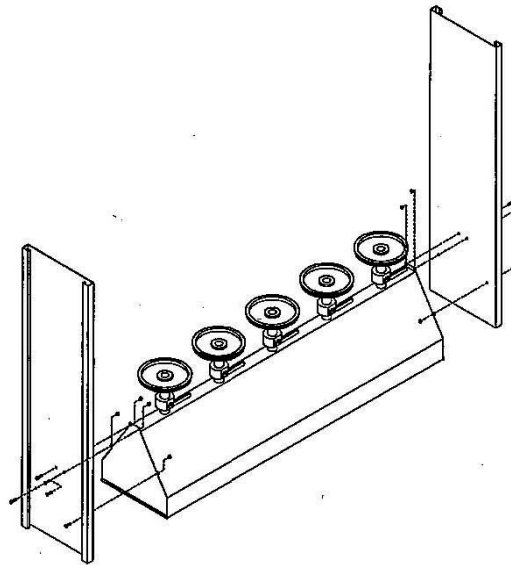

**STEP 2:**

- a. Use the M10 x 40 bolts to connect the bars at the corners to the side panels.
- b. Use the center bar connector to connect the four bars at the middle with the M10 x 40 bolts. Adjust the bars accordingly.

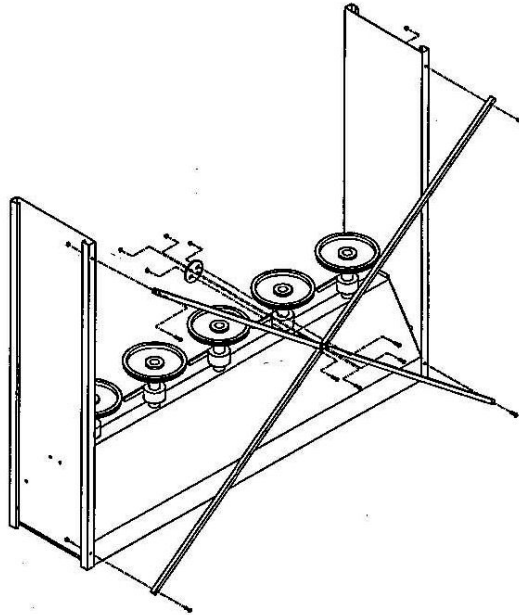

STEP 3: TURN OVER

- a. Turn the Dehydrator right side up. (See diagram.)
- b. Place the Dehydrator into the desired position.

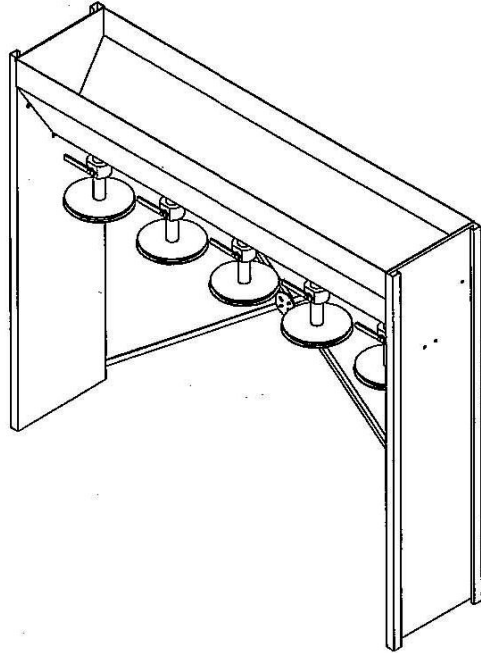

#### STEP 4: PIPE, POWER POINT

- a. Connect the water pipe to the side panel with the ON/OFF Power Point.
- b. Secure the water pipe with the M8 x 16 bolts.
- c. Connect the water hose to the water pipe and to the submersible pump. Secure it using the hose clamp. Place the submersible pump into the pit you want to clean.

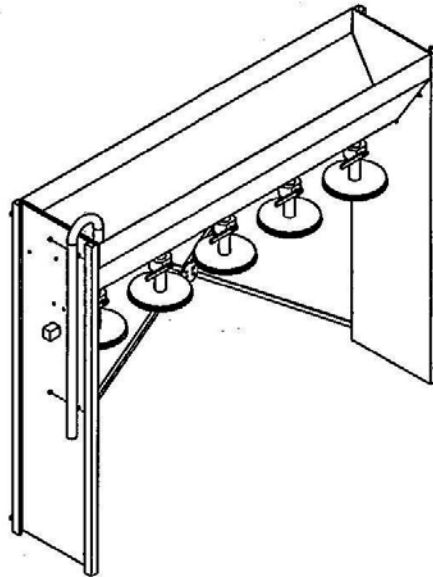



STEP 5:

- a. Slide the water tray into the Dehydrator facing the outlet pipes in the direction desired.
- b. Place the support panel on the top of the water tray.
- c. Mount the rods on both sides of the Dehydrator and attach the curtains, 2 on each side.

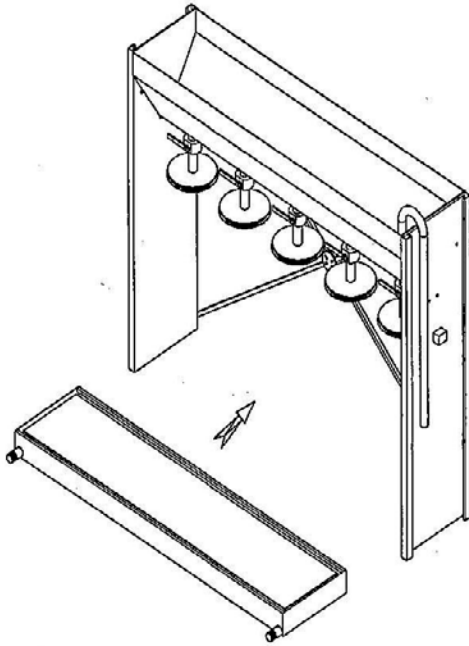



## ABACO MACHINES

### WARRANTY CERTIFICATE

In order to validate the warranty, it is mandatory to return the attached **Warranty Certificate**, duly completed, within **eight** days after purchase.

#### PERIOD

The warranty starts from the date of purchase (date on the distributor's invoice).

Warranty is valid for a period of **six months**.

#### WARRANTY

This warranty is limited to the replacement of parts recognized as defective by Abaco (excluding worn components and consumables).

The manufacturer is not responsible for any direct or indirect, material or immaterial damages caused to persons or property by failure of the machine or the non-operation of the machine.

#### WARRANTY CONDITIONS

To benefit from the warranty, it is mandatory to return the Warranty Certificate (attached below), duly completed, to Abaco within eight days after purchase.

In case of failure of the machine during the warranty period, our After –Sales Service Department will inform you of the appropriate method of dealing with your claim and advise you of your nearest approved service center.

#### EXCLUSIONS

Warranty does not apply for damages or failures caused by:

- Incorrect use, misuse, error in transportation, handling or maintenance.
- Wear items such as the SHACKLE are not covered unless proven defective, but **not** from general wear.
- Use of non-genuine parts or accessories.
- Use of incorrect specifications, i.e. stone slab thickness.